



# Small-Scale C&I Energy Storage Solution

SUN-50K-SG01HP3-EU-BM4 / SUN-80K-SG02HP3-EU-EM6

SUN-100K-PCSL01HP3

BOS-A

## SUN-50K-SG01HP3-EU-BM4 / SUN-80K-SG02HP3-EU-EM6

### Practicality & Universal Compatibility

- 100% unbalanced output
- AC couple to retrofit existing solar system
- Dual Independent battery circuit

### Versatile & High-Performance

- TOU function, Six time periods for battery charging/discharging
- Diesel generator-ready, VSG application

### Reliability & Scalability

- Max. 10 pcs parallel for on-grid and off-grid operation
- Seamless switching between on-grid and off-grid modes in less than 10ms

## BOS-A

### Intelligent Control

- Over-discharge/charge/current and temp protection

### 10-Year Warranty

- Safest LFP battery & Intelligent BMS

### Superior Output

- Support up to 160A current output

### 3U Rack Design

- Connectable to two inverter DC interfaces

### Flexible Expansion

- Support 7-21 packs in series
- Inverter 50-100kW, Battery 54-161kWh

### Battery Protection

- Auto-managed charge/discharge & Cell voltage balancing

# Small-Scale C&I Energy Storage Solution

Model	SUN-50K-SG01HP3-EU-BM4		
<b>Battery Input Data</b>			
Battery Type	Lithium-ion		
Battery Voltage Range (V)	160-800		
Max. Charging Current (A)	50+50		
Max. Discharging Current (A)	50+50		
Charging Strategy for Li-ion Battery	Self-adaption to BMS		
Number of Battery Input	2		
<b>PV String Input Data</b>			
Max. PV Access Power (W)	100000		
Max. PV Input Power (W)	80000		
Max. PV Input Voltage (V)	1000		
Start-up Voltage (V)	180		
MPPT Voltage Range (V)	150-850		
Rated PV Input Voltage (V)	600		
Max. Operating PV Input Current (A)	36+36+36+36		
Max. Input Short-Circuit Current (A)	55+55+55+55		
No. of MPP Trackers/ No. of Strings MPP Tracker	4/2+2+2+2		
<b>AC Input/Output Data</b>			
Rated AC Input/Output Active Power (W)	50000		
Max. AC Input/Output Apparent Power (VA)	55000		
Rated AC Input/Output Current (A)	75.8/72.5		
Max. AC Input/Output Current (A)	83.4/79.8		
Max. Continuous AC Passthrough (grid to load) (A)	200		
Peak Power (off-grid) (W)	1.5 times of rated power, 10s		
Power Factor Adjustment Range	0.8 leading to 0.8 lagging		
Rated Input/Output Voltage/Range (V)	220/380V, 230/400V 0.85Un-1.1Un		
Rated Input/Output Grid Frequency/Range(Hz)	50/45-55 60/55-65		
Grid Connection Form	3L+N+PE		
Total Current Harmonic Distortion THDi	<3% (of nominal power)		
DC Injection Current	<0.5% In		
<b>Efficiency</b>			
Max. Efficiency	97.60%		
Euro Efficiency	97.0%		
MPPT Efficiency	>99%		
<b>Equipment Protection</b>			
Integrated	DC Polarity Reverse Connection Protection, AC Output Overcurrent Protection, Thermal Protection, AC Output Overvoltage Protection, AC Output Short Circuit Protection, DC Component Monitoring, Overvoltage Load Drop Protection, Ground Fault Current Monitoring, Arc Fault Circuit Interrupter (optional), Power Network Monitoring, Island Protection Monitoring, Earth Fault Detection, DC Input Switch, DC Terminal Insulation Impedance Monitoring, Residual Current (RCD) Detection, Surge protection level		
Surge Protection Level	TYPE II(DC), TYPE II(AC)		
<b>Interface</b>			
Communication Interface	RS485/RS232/CAN		
Monitor Mode	GPRS/WIFI/Bluetooth/4G/LAN(optional)		
<b>General Data</b>			
Operating Temperature Range(°C)	-40 to +60°C, >45°C Derating		
Permissible Ambient Humidity	0-100%		
Permissible Altitude	2000m		
Noise (dB)	≤65		
Ingress Protection (IP) Rating	IP 65		
Inverter Topology	Non-Isolated		
Over Voltage Category	OVC II(DC), OVC III(AC)		
Cabinet Size (WxHxD mm)	527×894×294 (Excluding Connectors and Brackets)		
Weight (kg)	80		
Type of Cooling	Intelligent Air Cooling		
Warranty	5 Years/10 Years the Warranty Period Depends the Final Installation Site of Inverter, More Info Please Refer to Warranty Policy		
Grid Regulation	IEC 61727, IEC 62116, CEI 0-21, EN 50549, NRS 097, RD 140, UNE 217002, OVE-Richtlinie R25, G99, VDE-AR-N 4105		
Safety / EMC Standard	IEC/EN 61000-6-1/2/3/4, IEC/EN 62109-1, IEC/EN 62109-2		

# Small-Scale C&I Energy Storage Solution

Model	SUN-60K-SG02HP3 -EU-EM6	SUN-70K-SG02HP3 -EU-EM6	SUN-75K-SG02HP3 -EU-EM6	SUN-80K-SG02HP3 -EU-EM6
<b>Battery Input Data</b>				
Battery Type	Lithium-ion			
Battery Voltage Range (V)	160-1000			
Max. Charging Current (A)	80+80			
Max. Discharging Current (A)	80+80			
Charging Strategy for Li-ion Battery	Self-adaption to BMS			
Number of Battery Input	2			
<b>PV String Input Data</b>				
Max. PV Access Power (W)	120000	140000	150000	160000
Max. PV Input Power (W)	96000	112000	120000	128000
Max. PV Input Voltage (V)	1000			
Start-up Voltage (V)	180			
MPPT Voltage Range (V)	150-850			
Rated PV Input Voltage (V)	650			
Max. Operating PV Input Current (A)	36+36+36+36+36+36			
Max. Input Short-Circuit Current (A)	54+54+54+54+54+54			
No. of MPP Trackers/ No. of Strings MPP Tracker	6/2+2+2+2+2			
<b>AC Input/Output Data</b>				
Rated AC Input/Output Active Power(W)	60000	70000	75000	80000
Max. AC Input/Output Apparent Power(VA)	66000	77000	82500	88000
Rated AC Input/Output Current (A)	91/87	106.1/101.5	113.7/108.7	121.3/115.9
Max. AC Input/Output Current (A)	100/95.7	116.7/111.6	125/119.6	133.4/127.6
Max. Continuous AC Passthrough (grid to load) (A)	200			
Peak Power (off-grid) (W)	1.5 times of rated power, 10s			
Power Factor Adjustment Range	0.8 leading to 0.8 lagging			
Rated Input/Output Voltage/Range (V)	220/380V, 230/400V 0.85Un-1.1Un			
Rated Input/Output Grid Frequency/Range(Hz)	50/45-55 60/55-65			
Grid Connection Form	3L+N+PE			
Total Current Harmonic Distortion THDi	<3% (of nominal power)			
DC Injection Current	<0.5% In			
<b>Efficiency</b>				
Max. Efficiency	98.70%			
Euro Efficiency	98.10%			
MPPT Efficiency	>99%			
<b>Equipment Protection</b>				
Integrated	DC Polarity Reverse Connection Protection, AC Output Overcurrent Protection, Thermal Protection, AC Output Overvoltage Protection, AC Output Short Circuit Protection, DC Component Monitoring, Overvoltage Load Drop Protection, Ground Fault Current Monitoring, Arc Fault Circuit Interrupter (optional), Power Network Monitoring, Island Protection Monitoring, Earth Fault Detection, DC Input Switch, DC Terminal Insulation Impedance Monitoring, Residual Current (RCD) Detection, Surge protection level			
Surge Protection Level	TYPE II(DC), TYPE II(AC)			
<b>Interface</b>				
Communication Interface	RS485/RS232/CAN			
Monitor Mode	GPRS/WIFI/Bluetooth/4G/LAN(optional)			
<b>General Data</b>				
Operating Temperature Range(°C)	-40 to +60°C, >45 °C Derating			
Permissible Ambient Humidity	0-100%			
Permissible Altitude	3000m			
Noise (dB)	≤65			
Ingress Protection (IP) Rating	IP 65			
Inverter Topology	Non-Isolated			
Over Voltage Category	OVC II(DC), OVC III(AC)			
Cabinet Size (WxHxD mm)	606×927×314 (Excluding Connectors and Brackets)			
Weight (kg)	105			
Type of Cooling	Intelligent Air Cooling			
Warranty	5 Years/10 Years the Warranty Period Depends the Final Installation Site of Inverter, More Info Please Refer to Warranty Policy			
Grid Regulation	IEC 61727, IEC 62116, CEI 0-21, EN 50549, NRS 097, RD 140, UNE 217002, OVE-Richtlinie R25, G99, VDE-AR-N 4105			
Safety / EMC Standard	IEC/EN 61000-6-1/2/3/4, IEC/EN 62109-1, IEC/EN 62109-2			

# Small-Scale C&I Energy Storage Solution

PCS Model	SUN-100K-PCSL01HP3	SUN-125K-PCSL01HP3
<b>Battery Data</b>		
Battery Type	Lithium-ion	
Battery Voltage Range (V)	630-1000	
Max. Charging Current (A)	175	220
Max. Discharging Current (A)	175	220
Charging Strategy for Li-ion Battery	Self-adaption to BMS	
Number of Battery Input	1	
<b>AC Input/Output Data</b>		
Rated AC Input/Output Active Power (kW)	100	125
Max. AC Input/Output Apparent Power (kVA)	110	125
Rated AC Input/Output Current (A)	151.6/145	189.4/181.2
Max. AC Input/Output Current (A)	166.7/159.5	189.4/181.2
Rated Input/Output Voltage/Range(V)	220/380, 230/400 0.85Un-1.1Un	
Grid Connection Form	3L+N+PE	
Rated Input/Output Grid Frequency/Range	50Hz/45Hz-55Hz 60Hz/55Hz-65Hz	
Power Factor Adjustment Range	-1~1	
Total Current Harmonic Distortion THDi	<3% (of nominal power)	
DC Injection Current	<0.5% In	
<b>Efficiency</b>		
Max. Efficiency	98.5%	
Euro Efficiency	97.8%	
MPPT Efficiency	>99%	
PCS Model	SUN-MPPT-L01-EU-AM8	
<b>PV String Input Data</b>		
Max. PV Input Power (kW)	200	
Max. PV Input Voltage (V)	1000	
Start-up Voltage (V)	200	
MPPT Voltage Range (V)	180-850	
Full Load MPPT Voltage Range (V)	450-850	
Rated PV Input Voltage (V)	600	
Max. Operating PV Input Current (A)	40+40+40+40+40+40+40+40	
Max. Input Short-Circuit Current (A)	60+60+60+60+60+60+60+60	
No. of MPP Trackers	8	
<b>Efficiency</b>		
Max. Efficiency	>99%	
MPPT Efficiency	>99.9%	

# Small-Scale C&I Energy Storage Solution

## STS Module

## SUN-ST500L

### Grid Side Data

Rated AC Input/Output Active Power (kW)

500

Rated AC Input/Output Current (A)

725

Rated Input/Output Voltage(V)

220/380, 230/400 (three phase)

Grid Connection Form

3L/N/PE

Rated Input/Output Grid Frequency

50Hz/60Hz

### Load Side Data

Rated Output Active Power (kW)

500

Rated Output Current (A)

725

Rated Output Voltage(V)

220/380, 230/400 (three phase)

Grid Connection Form

3L/N/PE

Rated Output Grid Frequency

50Hz/60Hz

### GEN Side Data

Rated AC Input Active Power (kW)

500

Rated AC Input Current (A)

725

Rated Input Voltage(V)

220/380, 230/400 (three phase)

Grid Connection Form

3L/N/PE

Rated Input Grid Frequency

50Hz/60Hz

### Equipment Protection

Integrated

DC Polarity Reverse Connection Protection, AC Output Overcurrent Protection, Thermal Protection, AC Output Overvoltage Protection, AC Output Short Circuit Protection, DC Component Monitoring, Overvoltage Load Drop Protection, Ground Fault Current Monitoring, Arc Fault Circuit Interrupter (optional), Power Network Monitoring, Island Protection Monitoring, Earth Fault Detection, DC Input Switch, Surge protection level

Surge Protection Level

TYPE II(DC), TYPE II(AC)

### Interface

LCD/LED display

LCD

Communication Interface

WIFI, RS485, CAN, Meter

### General Data

Off grid switching time

<30ms

Operating Temperature Range(°C)

-25°Cto +60°C,>45°C Derating

Permissible Ambient Humidity

0-95%

Permissible Altitude

4000m

Ingress Protection(IP) Rating

IP 65(MPPT Module)

IP 65(PCS Module)

IP 20(STS Module)

Cabinet Size(W×H×D)[mm]

543×197.8×700(MPPT Module)

543×310×775(PCS Module)

543×575×866(STS Module)

Inverter Topology

Non-Isolated

Over Voltage Category

OVC II(DC), OVC III(AC)

Type of Cooling

Intelligent Air Cooling

Warranty

5 Years/10 Years  
the Warranty Period Depends the Final Installation Site of Inverter,  
More Info Please Refer to Warranty Policy

Grid Regulation

IEC 61727, IEC 62116, CEI 0-21, EN 50549, NRS 097, RD 140, UNE 217002,  
OVE-Richtlinie R25, G99, VDE-AR-N 4105

Safety/EMC Standard

IEC/EN 61000-6-1/2/3/4, IEC/EN 62109-1, IEC/EN 62109-2

# Small-Scale C&I Energy Storage Solution



## Model

**BOS-A**

### Main Parameters

Cell Chemistry	LiFePO <sub>4</sub>		
Module Energy ( kWh )	7.68		
Module Nominal Voltage ( V )	38.4		
Module Capacity ( Ah )	200		
Module Dimension ( W × D × H, mm )	601.5 × 520 × 135		
Module Weight Approximate ( kg )	70		
Battery Module Qty In Series ( Optional )	7	13	21
System Nominal Voltage ( V )	268.8	499.2	806.4
System Operating Voltage ( V )	235.2 ~ 306.6	436.8 ~ 569.4	705.6 ~ 919.8
System Energy ( kWh )	53.76	99.84	161.28
System Usable Energy ( kWh ) <sup>1</sup>	48.38	89.85	145.15
Charge / Discharge <sup>2</sup> Current ( A )	Recommend		100
	Max		160
Working Temperature ( °C )	Charge : 0 ~ 55 / Discharge : -20 ~ 55		
Status Indicator	Yellow : Battery High Voltage Power On Red : Battery System Alarm		
Communication Port	CAN2.0		
Humidity	5% ~ 85%RH		
Altitude	≤3000m		
IP Rating of Enclosure	IP20		
Dimension ( W × D × H, mm )	610 × 610 × 1900	610 × 610 × 2350	( 610 × 610 × 1900 ) × 2
Weight Approximate ( kg )	558	985	1586
Installation Location	Rack-Mounted		
Storage Temperature ( °C )	0 ~ 35		
Recommend Depth of Discharge	90%		
Cycle Life	≥6000 ( 25±2°C, 0.5C / 0.5C, EOL70% )		
Warranty <sup>3</sup>	10 years		
Certification	CE / IEC 62619 / IEC 62040 / UN38.3 / VDE-2510		

1. DC Usable Energy, test conditions : 90%DOD, 0.3C charge & discharge at 25°C. System usable energy may vary due to system configuration parameters.

2. The current is affected by temperature and SOC.

3. The warranty is due whichever reached first of warranty period or life cycle power.

# Small-Scale C&I Energy Storage Solution

Model

SUN-50K-SG01HP3-EU-BM4

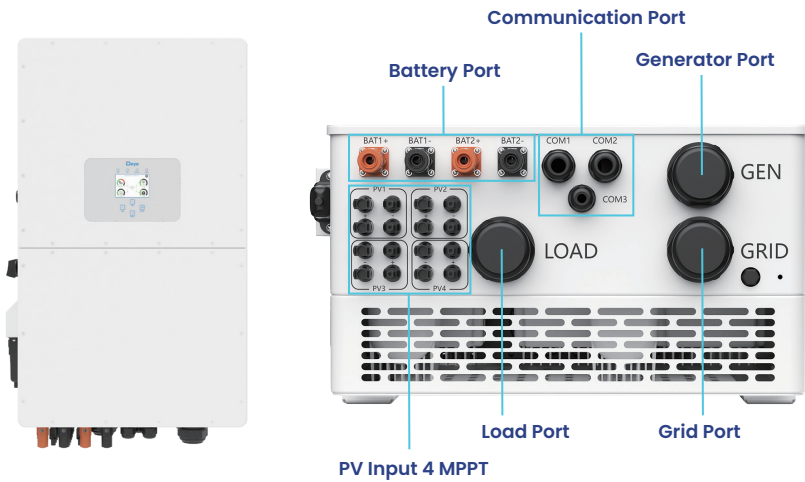

- ⊙ Battery Port: Dual independent battery circuit port, supporting multiple brand battery connection and battery voltage range 160-800V.
- ⊙ Communication Port: Serve as communicate with battery and data exchange between inverter and extra devices.
- ⊙ Load Port: Offer AC power to connected loads.
- ⊙ Grid Port: Connect to utility grid, for bidirectional power transfer: importing from and exporting to the grid.
- ⊙ Generator Port: Connect to diesel generator for backup power supply during outages, also can connect with existing solar inverter for AC Coupling.
- ⊙ PV Input: Connect to PV panels with 4 MPPTs.

Model

SUN-80K-SG02HP3-EU-EM6

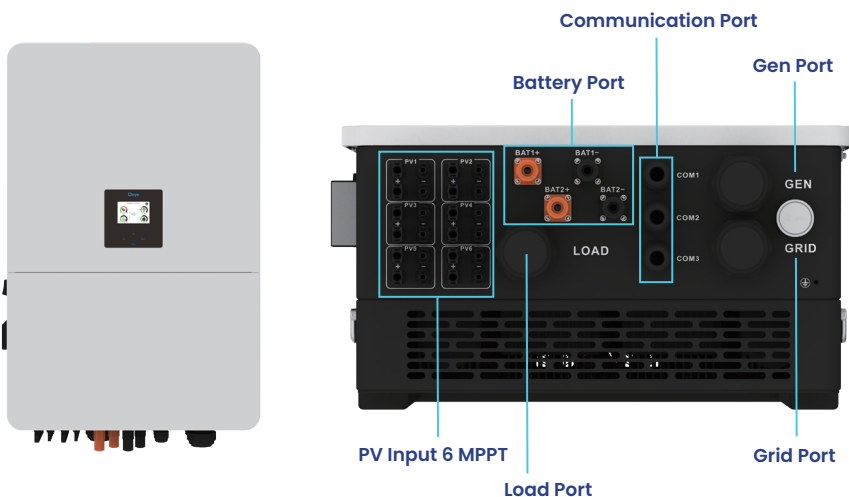

- ⊙ Battery Port: Dual independent battery circuit port, supporting multiple brand battery connection and battery voltage range 160-1000V.
- ⊙ Communication Port: Serve as communicate with battery and data exchange between inverter and extra devices.
- ⊙ Load Port: Offer AC power to connected loads.
- ⊙ Grid Port: Connect to utility grid, for bidirectional power transfer: importing from and exporting to the grid.
- ⊙ Generator Port: Connect to diesel generator for backup power supply during outages, also can connect with existing solar inverter for AC Coupling.
- ⊙ PV Input: Connect to PV panels with 6 MPPTs.

# Small-Scale C&I Energy Storage Solution

## STS Module

Smoothly switch between on-grid, off-grid, and diesel generator modes with a switching time of less than 10ms. Each diesel, load, and grid connection is independent, with each path supporting 500kW.

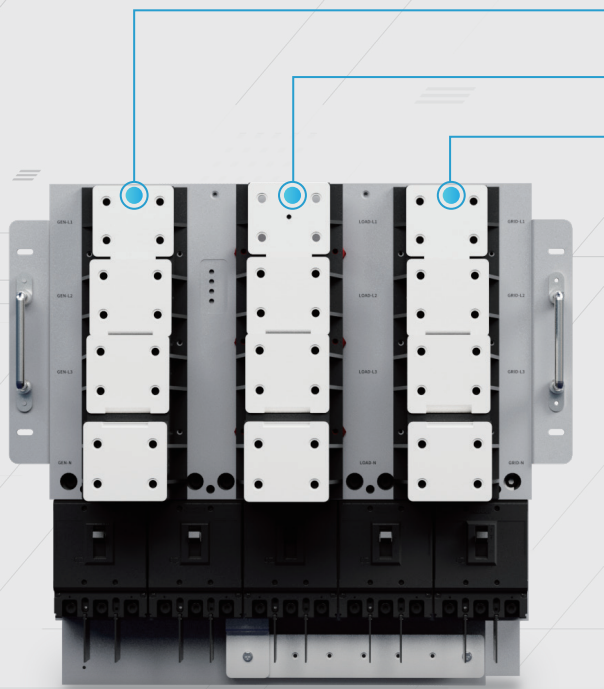

GEN Port

Load Port

Grid Port

### 500kW STS Module

- ◎ Switching capacity of **500kW**.
- ◎ One STS can be paired with **five** PCS units.
- ◎ Enables smooth switching between on-grid, off-grid, and diesel generator modes.
- ◎ Switching time of less than **10ms**.

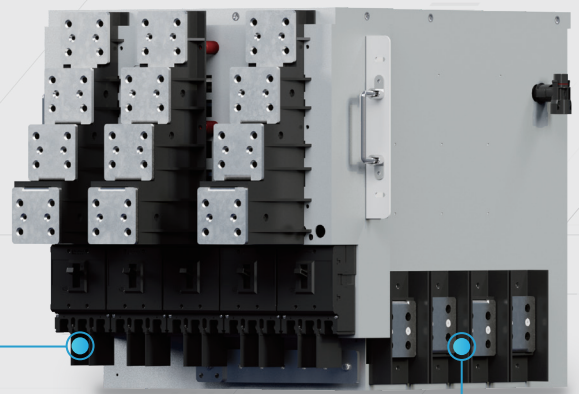

PCS Connection Point

STS AC Parallel Port

## MPPT Module & PCS Module

### MPPT Module

- ◎ Max. PV input of **200kW**.
- ◎ Supports **20A** high-current modules.

### 100kW/125kW PCS Module

- ◎ Max. charge and discharge current **220A**.
- ◎ Max. efficiency of **98.5%**.
- ◎ Supports up to **20** units in parallel.
- ◎ System rated power up to **2.5MW**.
- ◎ Eliminating the need for additional EMS.
- ◎ Integrates zero-export and time-of-use control functions.
- ◎ Supports instantaneous peak power up to **170%** of rated power.

PV Input  
8 MPPT

CAN/RS485

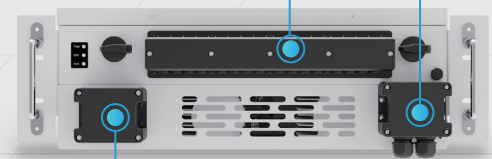

DC Port

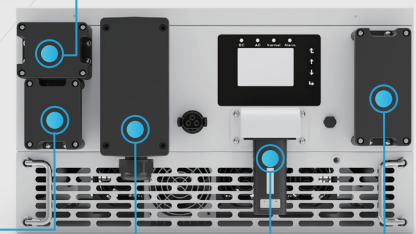

Battery Port

CT/Meter/BMS/  
MPPT/Parallel

Data Logger

AC Output

# Small-Scale C&I Energy Storage Solution

Model	BOS-A-PDU-2
Operating Voltage	200~1000Vdc
Max.Charge/Discharge Current	160A
Operating Temperature	-20~65°C
Ingress Protection	IP20
DC Input Rating	12±2%V/4.15A
Details	632×572×142.2(W×H×D),21kg

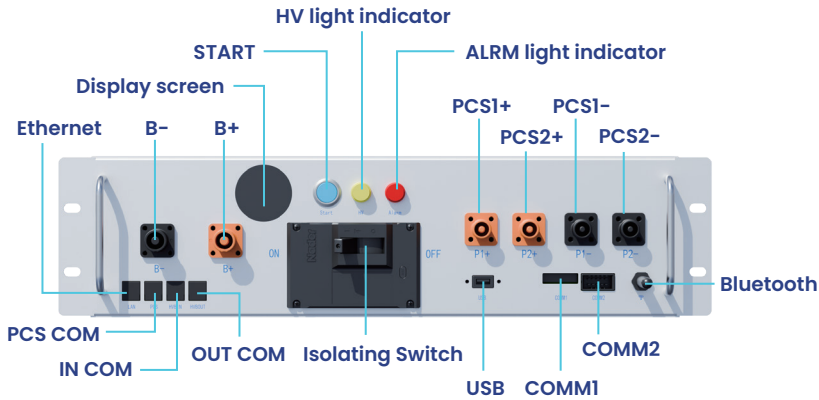

- © Ethernet:Features not yet developed.
- © PCS COM:PCS COM battery communication terminal: used to output battery information to the inverter.
- © IN COM:Connection position with previous BOS-A-PDU-4 communication input.
- © OUT COM:Connection position with next BOS-A-PDU-4 communication output.

- © Isolating Switch:It is used to manually control the connection between the battery rack and external devices.
- © USB:BMS upgrade port and storage expansion port.
- © COMM1:Connection position of external 12VDC power supply.
- © COMM2:Used for communication and providing power.
- © Bluetooth:The mobile APP connects to the data acquisition rod of the energy storage system.
- © B+:Battery common positive connection position (red).
- © B-:Battery common negative connection position (black).
- © Display screen:Display SOC and fault codes.
- © START:A start switch of 12VDC power inside the high-voltage control box.
- © HV light indicator:High-voltage hazard indicator (yellow).
- © ALRM light indicator:Battery system fault alarm indicator (red).
- © PCS1+:First PCS positive connection position (orange).
- © PCS2+:Second PCS positive terminal connection position (orange).
- © PCS1-:First PCS negative connection position (black).
- © PCS2-:Second PCS negative connection position (black).

Model	BOS-A-Pack7.68		
Nominal Capacity	200Ah	Ingress Protection	IP20
Nominal Energy	7.68kWh	Operating Temperature(Charge)	0~55°C
Nominal Voltage	38.4Vdc	Operating Temperature(Discharge)	-20~55°C
Nominal Charge/Discharge Current	160A	Storage Temperature	0~35°C
Details	632×576×135.2(W×H×D),66kg		

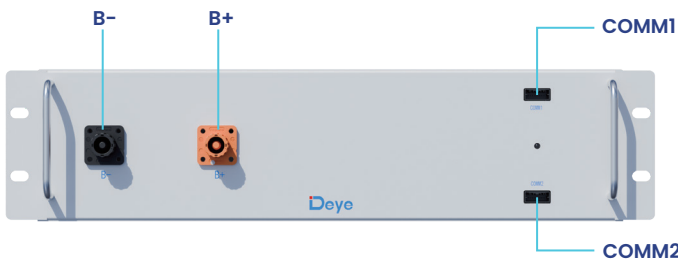

- © B-:Battery module negative pole (black).
- © B+:Battery module positive pole (orange).
- © COMM1:Used for communication and providing power.
- © COMM2:Used for communication and providing power.

# Small-Scale C&I Energy Storage Solution

Model

BOS-A

## BOS-A-Rack9 \*2

Can install 16 pcs batteries and 1 pcs High Voltage Battery cluster control box.

Dimension ( W × D × H )  
Weight Approximate

1220 × 610 × 1600mm  
84kg

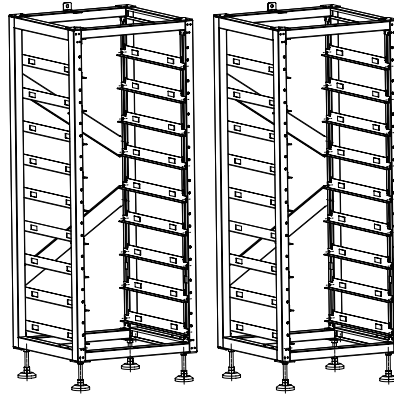

## BOS-A-Rack11 BOS-A-Rack11 \*2

Can install 10 pcs batteries and 1 pcs High Voltage Battery cluster control box.  
Can install 21 pcs batteries and 1 pcs High Voltage Battery cluster control box.

Dimension ( W × D × H )  
Weight Approximate

610 × 610 × 1900mm  
47kg

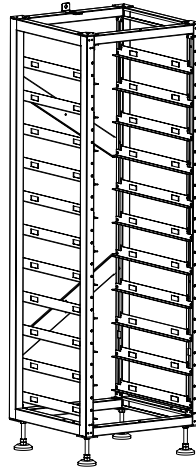

1220 × 610 × 1900mm  
94kg

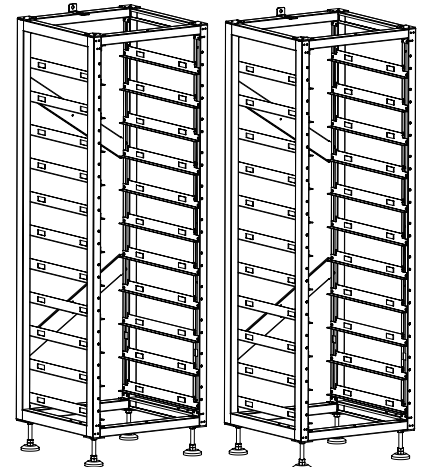

## BOS-A-Rack14

Can install 13 pcs batteries and 1 pcs High Voltage Battery cluster control box.

Dimension ( W × D × H )  
Weight Approximate

610 × 610 × 2350mm  
55kg

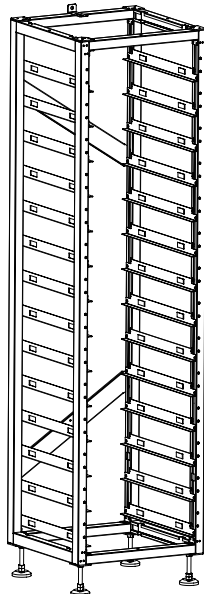

# Small-Scale C&I Energy Storage Solution

## Backup Power Duration Plan

	1 hours		2 hours		4 hours	
Hybrid inverter power	100kW	50kW	80kW	50kW	80kW	
Battery model	BOS-A160	BOS-A100	BOS-A160	BOS-A100	BOS-A160	
Number of batteries	1 pc	1 pc	1 pc	2 pcs	2 pcs	

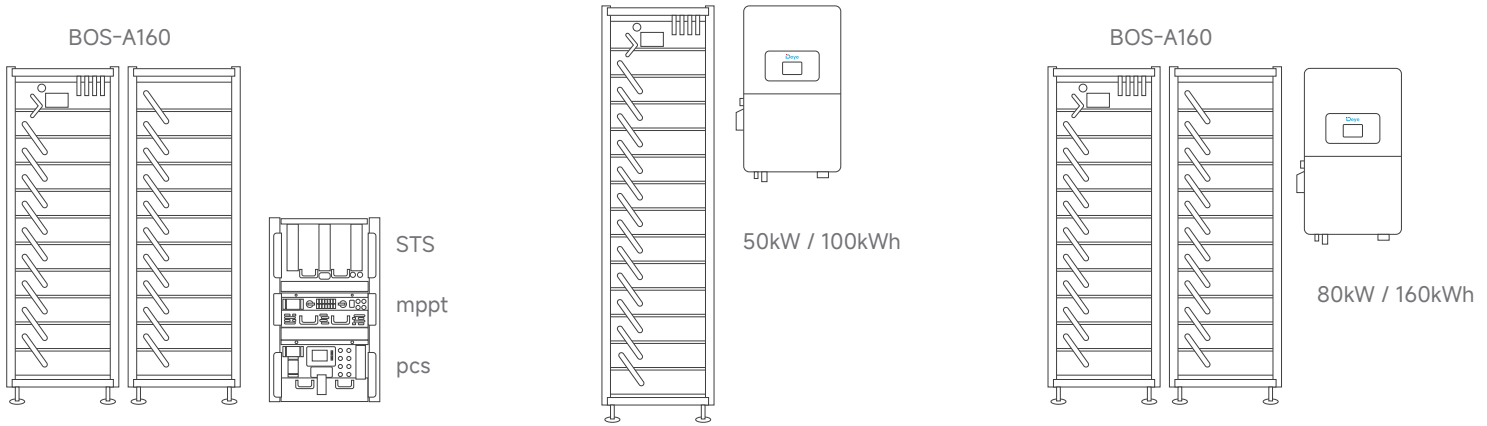

## Typical Application Scenarios

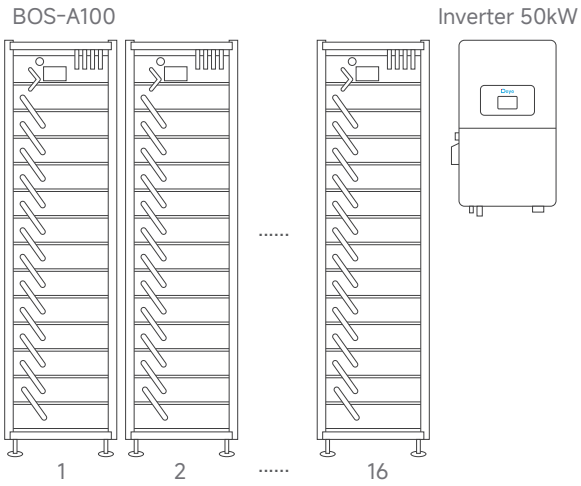

Maximum support for 16 racks of batteries in parallel

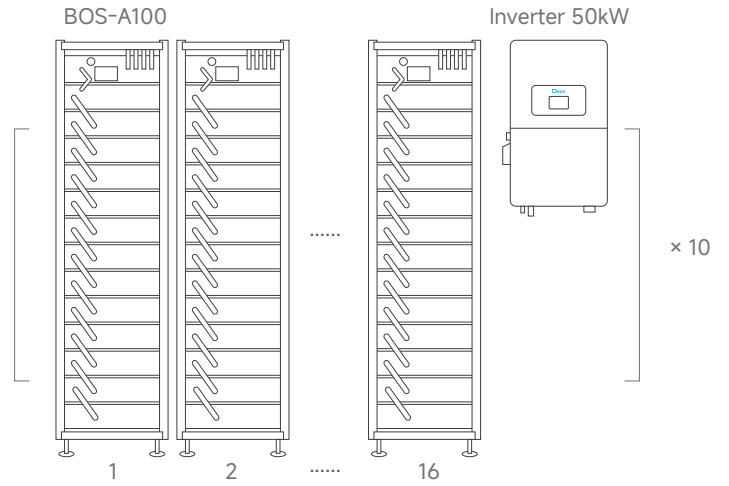

Maximum support for 10 inverters in AC parallel operation

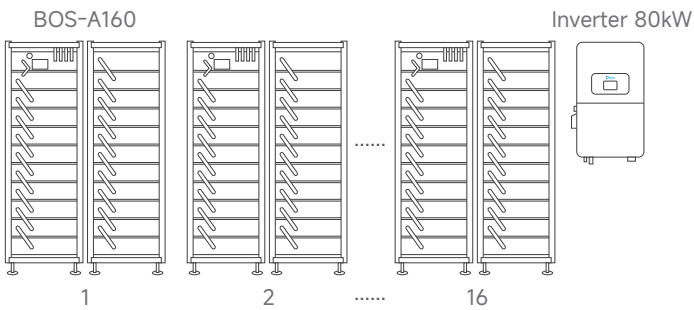

Maximum support for 16 clusters of batteries in parallel

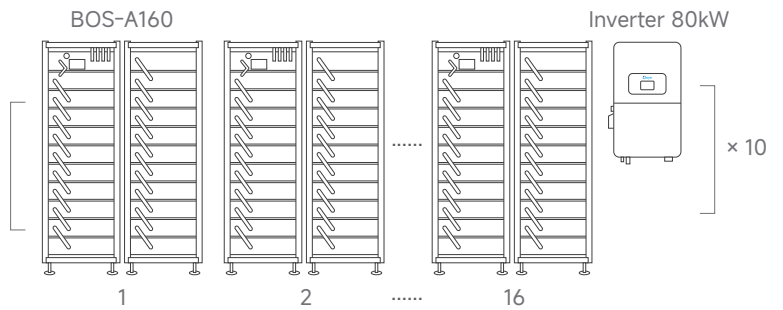

Maximum support for 10 inverters in AC parallel operation

# Deye Cloud

## All-in-one Energy & Device Management Platform

-  Unlock Significant Savings
-  Individual Add-On for Dynamic Tariff
-  Intelligent Charging/Discharging Strategies
-  Tailored Solution to Deye Devices
-  Real-time Equipment Monitoring





## Smarten Up Your Home Energy

Download Deye Cloud APP to join us!  
Embrace a seamless, effortless energy experience that's both eco-friendly and budget-friendly with our intelligent assistant

  
**All in One**  
Smarter home energy and device management

  
**Cloud-edge Collaboration**  
Faster and more efficient data processing

  
**Accelerated Connectivity**  
Optimized for speed and performance

  
**Advanced Smart Energy**  
A smarter way to manage your electricity bills